

ULTEM™ 9085 Filament

AEROSPACE-READY MATERIAL

ULTEM™ 9085 Filament is a high performance thermoplastic that exhibits excellent flame, smoke, and toxicity (FST) characteristics. Optimized for production aerospace applications, ULTEM™ Filament brings Markforged's CFR technology to a new realm of parts. ULTEM™ Filament is available in Markforged's new 3200cc XL spool — four times larger than our standard spools.

Carbon Fiber HT and Carbon Fiber HT-A are specialized variants of Markforged's Continuous Carbon Fiber designed for use with ULTEM™ Filament. Capable of yielding aluminum strength parts, they can be precisely laid down in a wide variety of geometries. Users can trace curved features, reinforce holes, and mimic unidirectional fiber layups — all within a few clicks.

ULTEM™ 9085 Filament, Carbon Fiber HT, and Carbon Fiber HT-A are only printed on the Markforged FX20™. ULTEM™ 9085 Filament parts are compatible with Support for ULTEM™ Filament, a dedicated support material printed out of a second nozzle.

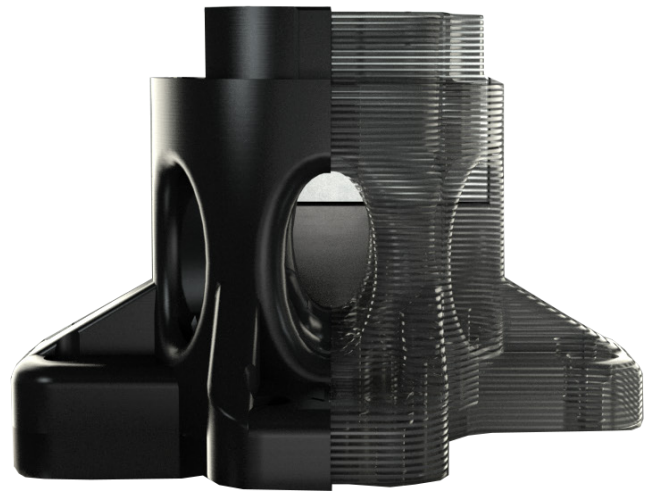

| Physical Properties | Unit | Test | ULTEM 9085™ Filament XZ Orientation ¹ | Test | Carbon Fiber HT (CFR) ² | Carbon Fiber HT-A (CFR) ^{2 3} |
|--------------------------|-------------------|-----------|--|-----------|------------------------------------|--|
| Tensile strength | MPa (ksi) | D638 | 76.5 ± 5.0 (11.1 ± 0.72) | D3039 | 800 (116) | 800 (116) |
| Tensile modulus | GPa (ksi) | D638 | 2.5 ± 0.1 (366.9 ± 8.7) | D3039 | 69 (10,005) | 69 (10,005) |
| Tensile strain at break | % | D638 | 5.7 ± 1.0 | D3039 | 1.6 | 1.6 |
| Flexural strength | MPa (ksi) | D790 | 134.5 ± 3.5 (19.5 ± 0.5) | D790 | 439.5 (63.7) | 529.7 (76.8) |
| Flexural modulus | GPa (ksi) | D790 | 2.6 ± 0.1 (369.8 ± 10.2) | D790 | 50.3 (7,291.1) | 53.3 (7,730.5) |
| Flexural strain at break | % | D790 | 7.9 ± 0.2 | D790 | 1.0 | 1.1 |
| Compressive strength | MPa (ksi) | D695 | — | D695 | 300 (43.5) | 300 (43.5) |
| Compressive modulus | GPa (ksi) | D695 | — | D695 | 59 (8,557) | 59 (8,557) |
| Izod Impact - notched | J/m (ft·lb/in) | D256-10 A | 70 (1.3) | D256-10 A | 810 (15.2) | 810 (15.2) |
| Density | g/cm ³ | — | 1.12 ± 0.02 | — | 1.20 | 1.20 |
| HDT (66 psi) | deg C (deg F) | D648 B | 175 (347) | D648 B | 190 (374) | 190 (374) |
| HDT (264 psi) | deg C (deg F) | D648 B | 175 (347) | D648 B | 190 (374) | 190 (374) |

These representative data were tested, measured, or calculated using standard methods and are subject to change without notice. Markforged makes no warranties of any kind, express or implied, including, but not limited to, the warranties of merchantability, fitness for a particular use, or warranty against patent infringement; and assumes no liability in connection with the use of this information. The data listed here should not be used to establish design, quality control, or specification limits, and are not intended to substitute for your own testing to determine suitability for your particular application. Nothing in this sheet is to be construed as a license to operate under or a recommendation to infringe upon any intellectual property right.

¹ Data provided is based on 250um layer height, which is the default print setting and the only layer height compatible with CFR.

² CF-HT and CF-HT-A values are derived from pure fiber test specimens. Actual part strength will depend on the amount and pathing of fiber in the part.

³ CF-HT-A is recommend for material and system qualification.

Printer & Material Compatibility

ULTEM™ 9085 Filament

Available for use on the FX20 and compatible with Support for ULTEM™ Filament.

Can only be reinforced with Carbon Fiber HT and Carbon Fiber HT-A.

Carbon Fiber HT and Carbon Fiber HT-A

Available for use on the FX20.

Only compatible as a reinforcement for ULTEM™ 9085 Filament and Vega™.

Future Data

ULTEM™ 9085 Filament, Carbon Fiber HT, and Carbon Fiber HT-A are undergoing more tests which will provide additional results after completion, including:

Full mechanical data

Glass transition temperature

Coefficient of thermal expansion (CTE)

UV exposure

Fluid sensitivity to common aerospace fluids including fuels, lubricants, and cleaning agents

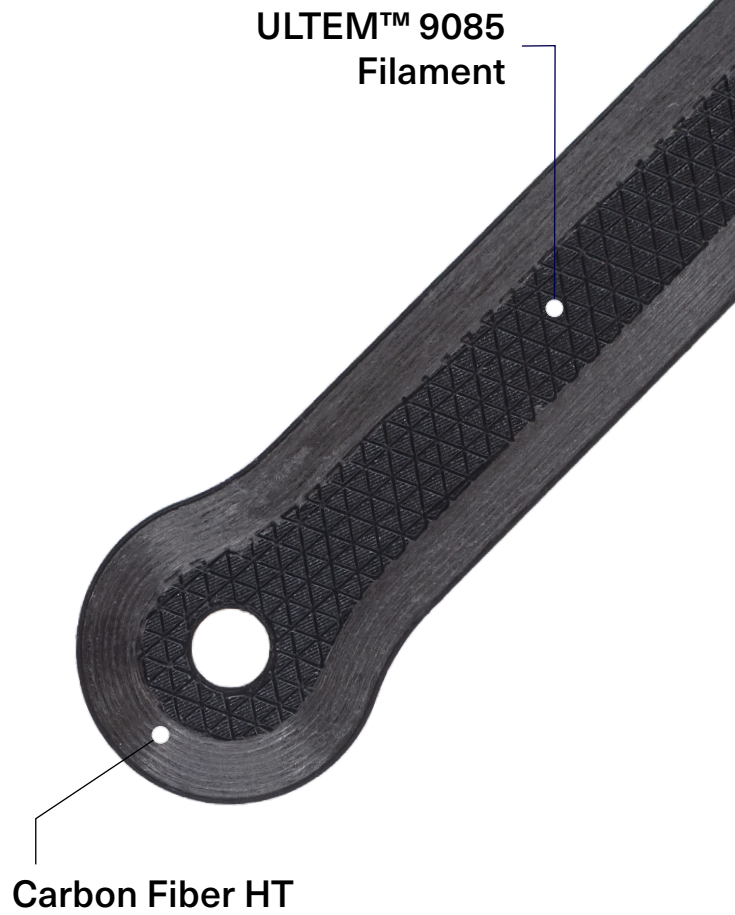

Directional Mechanical Properties of ULTEM™ 9085 Filament

The mechanical properties of 3D printed materials may vary with print orientation. In tension, most parts are strongest when the print orientation and loading direction are parallel, and weakest when the print orientation and loading direction are perpendicular.

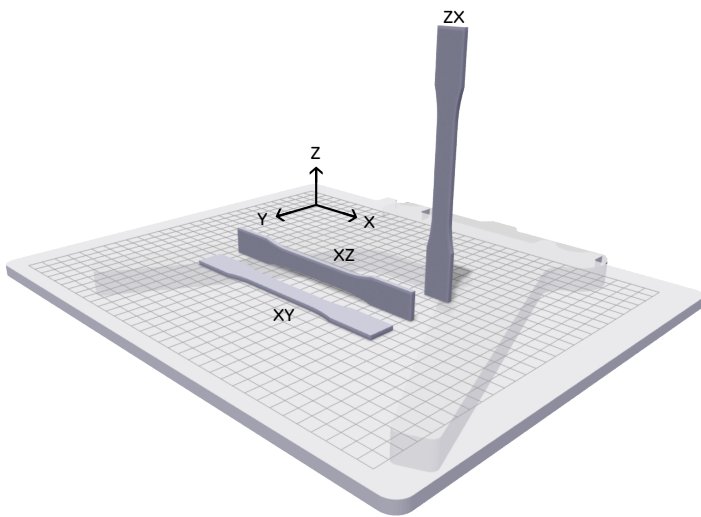

| Property ⁴ | Print orientation | Average | Average |
|-------------------------|-------------------|---------------------|---------------------|
| | | 125 μm layer height | 250 μm layer height |
| Tensile strength (MPa) | XY | 71.2 ± 8.7 | 56.2 ± 4.1 |
| | XZ | 92.0 ± 1.7 | 76.5 ± 5.0 |
| | ZX | 47.6 ± 5.2 | 42.5 ± 1.1 |
| Tensile modulus (GPa) | XY | 2.5 ± 0.2 | 2.0 ± 0.1 |
| | XZ | 2.9 ± 0.1 | 2.5 ± 0.1 |
| | ZX | 2.5 ± 0.1 | 2.1 ± 0.1 |
| Elongation at break (%) | XY | 5.6 ± 1.2 | 7.4 ± 0.5 |
| | XZ | 6.5 ± 0.4 | 5.7 ± 1.0 |
| | ZX | 2.4 ± 1.1 | 2.3 ± 0.8 |

⁴The ULTEM™ and 9085 trademarks are used under license from SABIC, its affiliates or subsidiaries.

To learn more about specific testing conditions or to request test parts for internal testing, contact a Markforged representative. All customer parts should be tested in accordance to customer's specifications.

This data sheet is preliminary and includes some estimated values. Values will be updated when full material testing is complete.

Markforged makes no warranties of any kind, express or implied, including, but not limited to, the warranties of merchantability, fitness for a particular use, or warranty against patent infringement; and assumes no liability in connection with the use of this information. The data listed here should not be used to establish design, quality control, or specification limits, and are not intended to substitute for your own testing to determine suitability for your particular application. Nothing in this sheet is to be construed as a license to operate under or a recommendation to infringe upon any intellectual property right.

⁴XY and XZ specimens were printed with default solid fill settings. ZX specimens were printed with solid fill settings with 6 walls and 4 floors.